

### S360-Гайка за Т-болт (DIN 508 \ UNI 5531)

Стр.1 от 1

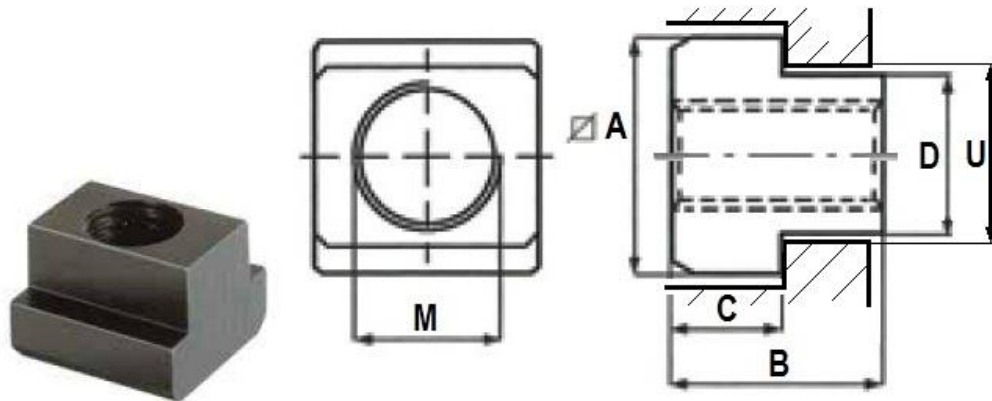

Материал: Стомана клас 8G

Код	M	D	A	B	C	U	гр
S360.06008	6	5,7	13	10	6	8	9
S360.08010	8	9,7	15	12	6	10	12
S360.08012	8	11,7	18	14	7	12	22
S360.10012	10	11,7	18	14	7	12	20
S360.08014	8	13,7	22	16	8	14	41
S360.10014	10	13,7	22	16	8	14	37
S360.12014	12	13,7	22	16	8	14	35
S360.08016	8	15,7	25	18	9	16	61
S360.10016	10	15,7	25	18	9	16	59
S360.12016	12	15,7	25	18	9	16	56
S360.14016	14	15,7	25	18	9	16	52
S360.08018	8	17,7	28	20	10	18	91
S360.10018	10	17,7	28	20	10	18	87
S360.12018	12	17,7	28	20	10	18	82
S360.14018	14	17,7	28	20	10	18	70
S360.16018	16	17,7	28	20	10	18	60
S360.16020	16	19,7	32	24	12	20	110
S360.18020	18	19,7	32	24	12	20	100
S360.16022	16	21,7	35	28	14	22	176
S360.18022	18	21,7	35	28	14	22	163
S360.20022	20	21,7	35	28	14	22	155
S360.16024	16	23,7	40	32	16	24	260
S360.20024	20	23,7	40	32	16	24	235
S360.22024	22	23,7	40	32	16	24	220
S360.16028	16	27,7	44	35	18	28	383
S360.20028	20	27,7	44	35	18	28	355
S360.22028	22	27,7	44	35	18	28	340
S360.24028	24	27,7	44	35	18	28	322
S360.24030	24	29,7	48	38	19	30	440
S360.27032	27	31,6	50	40	20	32	460
S360.30036	30	35,6	54	44	22	36	590
S360.36042	36	41,6	65	52	26	42	1010